

MOUNTING PROCEDURE

KIT WINDSHIELD BMW R-NINET

BT1300

WWW.BARRACUDAMOTO.COM

MOUNTIGN PROCEDURE:

- PRE-ASSEMBLING THE SUPPORT BRACKET OF WINDSHIELD LOCKING WITH SCREW 5X10 AND THE TURNED THREAD INTO THE KIT LIKE IN THE SCHEME;
- REMOVE THE ORIGINAL LIGHT AND POSITION THE BRACKET ALREADY ASSEMBLED WITH THE 8X45 CREWS, AFTER PUT AGAIN THE LIGHT IN THE ORIGINAL POSITION;
- PUT THE SQUADRE STICKERS TO PROTECT THE WINDSHIELD BEHIND THE BRACKET LIKE PHOTOS, ON THE POINTS LIGHTING

MOTORCYCLE FIXING

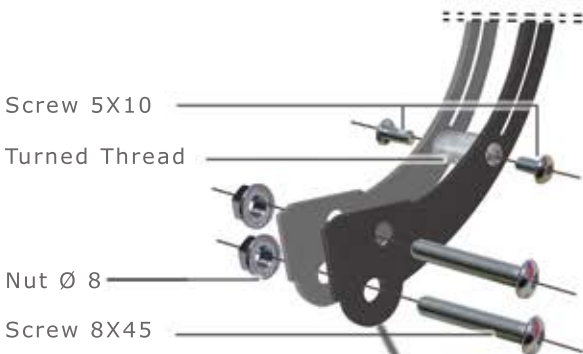

WINDSHIELD FIXING

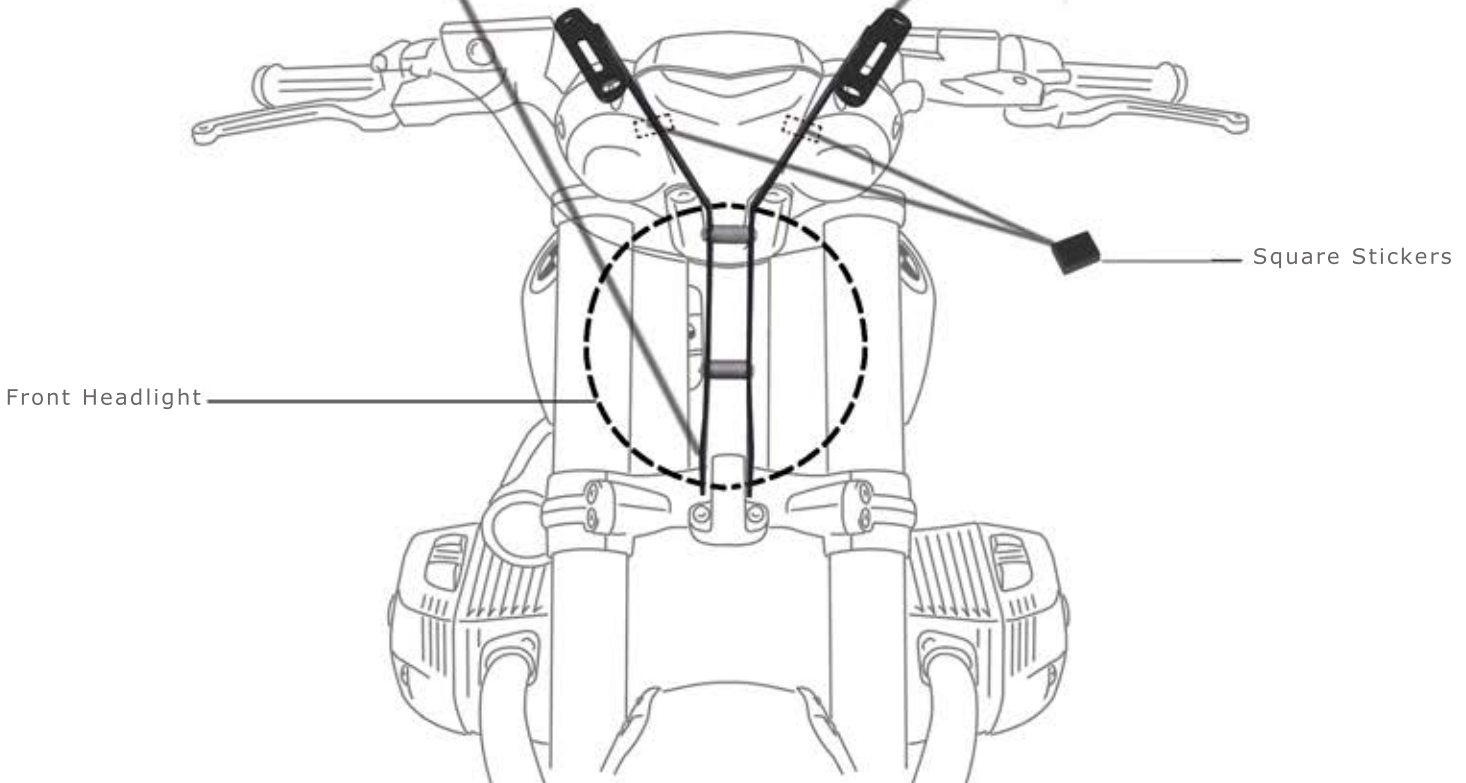
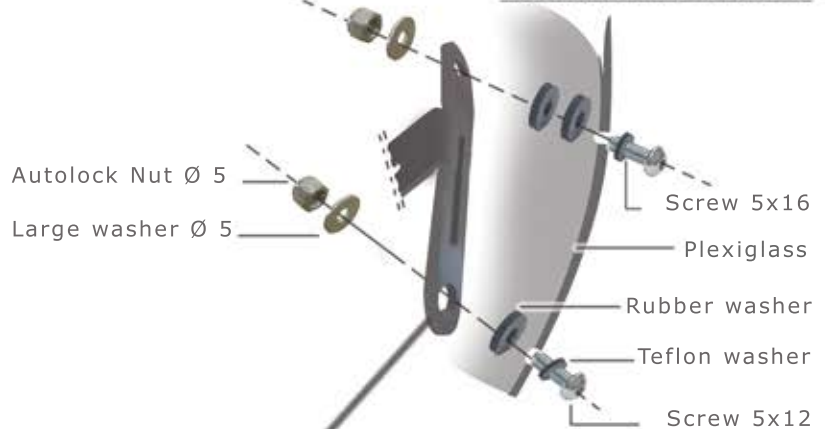

NOTE: FIX THE WINDSHIELD ONLY AFTER FIX THE BRACKETS.
DON'T LOCK TOO MUCH TO AVOID POSSIBLE BROKEN OF PLEXIGLASS.

ISTRUZIONI DI MONTAGGIO**KIT CUPOLINO
BMW R-NINET****BT1300****KIT**

- X1. PLEXIGLASS
- X2. STAFFE SPECIFICHE
- X4. BRUGOLE "TESTA BOMBATA" 5X12
- X4. BRUGOLE "TESTA BOMBATA" 5X16
- X2. BRUGOLA "TESTA BOMBATA" 8X45
- X2. TORNITO FILETTATO
- X4. DADI AUTOBLOCCANTI Ø 5
- X2. DADO ZIGRINATO Ø 8
- X4. RONDELLA Ø 5 LARGA
- X4. RONDELLE TEFLON Ø 5
- X6. RONDELLE DI GOMMA
- X2. QUADROTTI ADESIVI

WWW.BARRACUDAMOTO.COM**PROCEDURA MONTAGGIO:**

- PRE-ASSEMBLARE LE STAFFE SUPPORTO CUPOLINO SERRANDOLE CON LE BRUGOLE 5X12 E I TORNITI FILETTATI IN DOTAZIONE COME DA SCHEMA;
- RIMUOVERE IL FARO ORIGINALE DALLA SUA SEDE E POSIZIONARE LE STAFFE PRECEDENTEMENTE MONTATE CON BRUGOLE 8X45, IN SEGUITO RILOCARE IL FARO IN POSIZIONE ORIGINALE;
- POSIZIONARE QUADROTTI ADESIVI PER PROTEGGERE IL CRUSCOTTO NEI PUNTI EVIDENZIATI DIETRO LE STAFFE COME DA FOTO.

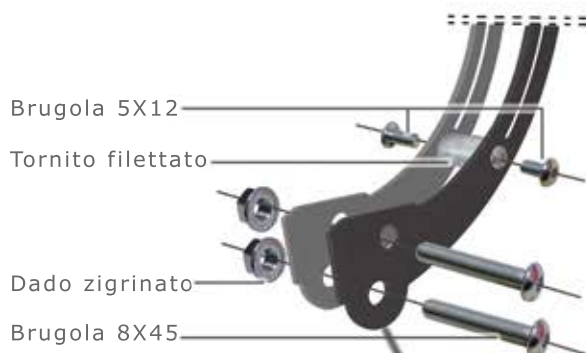
FISSAGGIO MOTO

Dado Ø 5 Autobloccante

Rondella Ø 5 larga

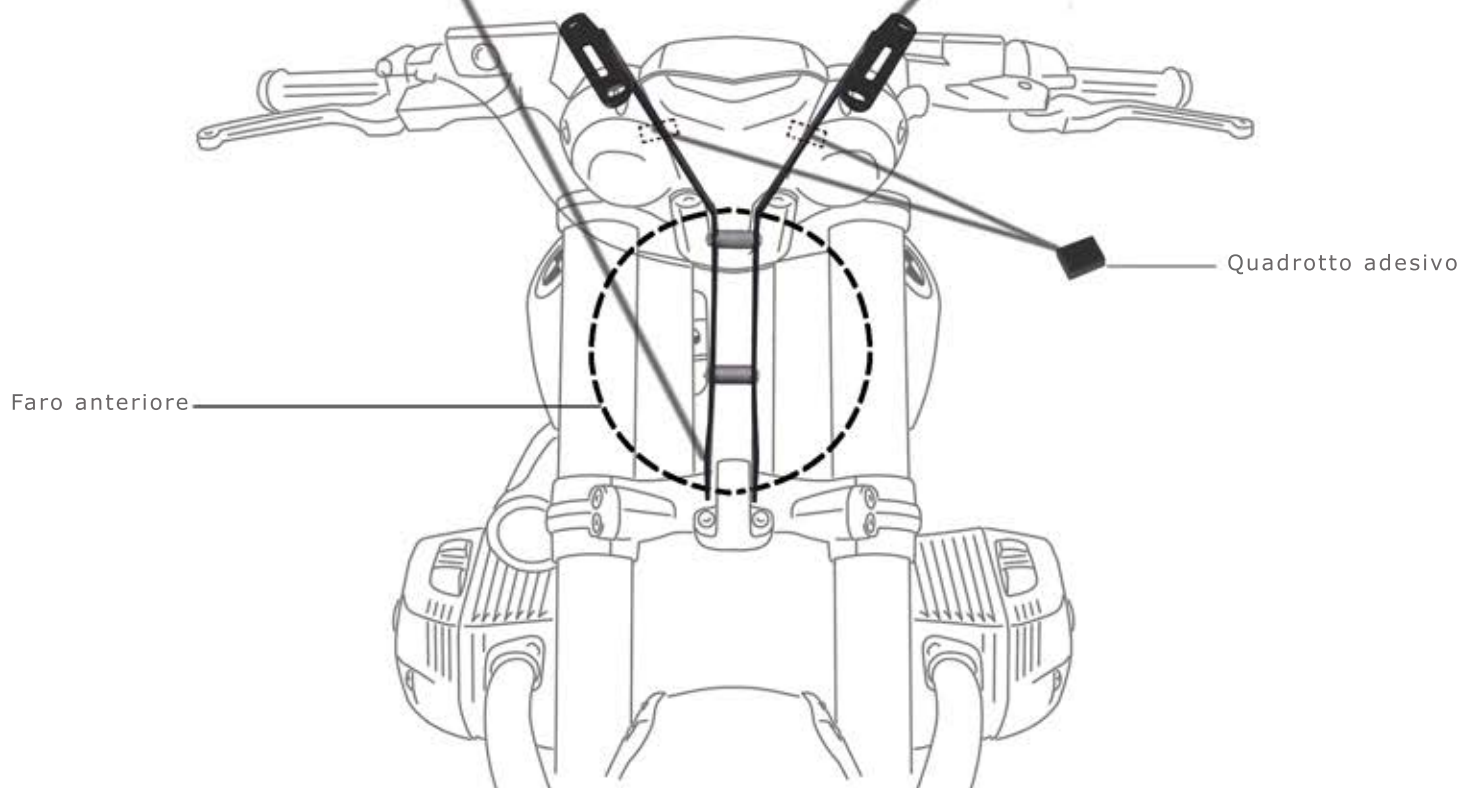
FISSAGGIO CUPOLINO

NOTE: SERRARE IL CUPOLINO SOLO DOPO AVER STRETTO LE STAFFE.
NON SERRARE IN MODO ECCESSIVO ONDE EVITARE ROTTURE DEL PLEXIGLASS.