

MOUNTING PROCEDURE

KIT SAVE CARTER
YAMAHA R1 '15 '16 - MT-10

YP1101-15

WWW.BARRACUDAMOTO.COM

KIT

X2. PVC HEAD
X2. CRASH PAD BASE
X1. THICKNESS H.55 (LEFT SIDE)
X1. THICKNESS H.20 (RIGHT SIDE)
X1. SCREW 12X80 (RIGHT SIDE)
X1. SCREW 12X110 (LEFT SIDE)

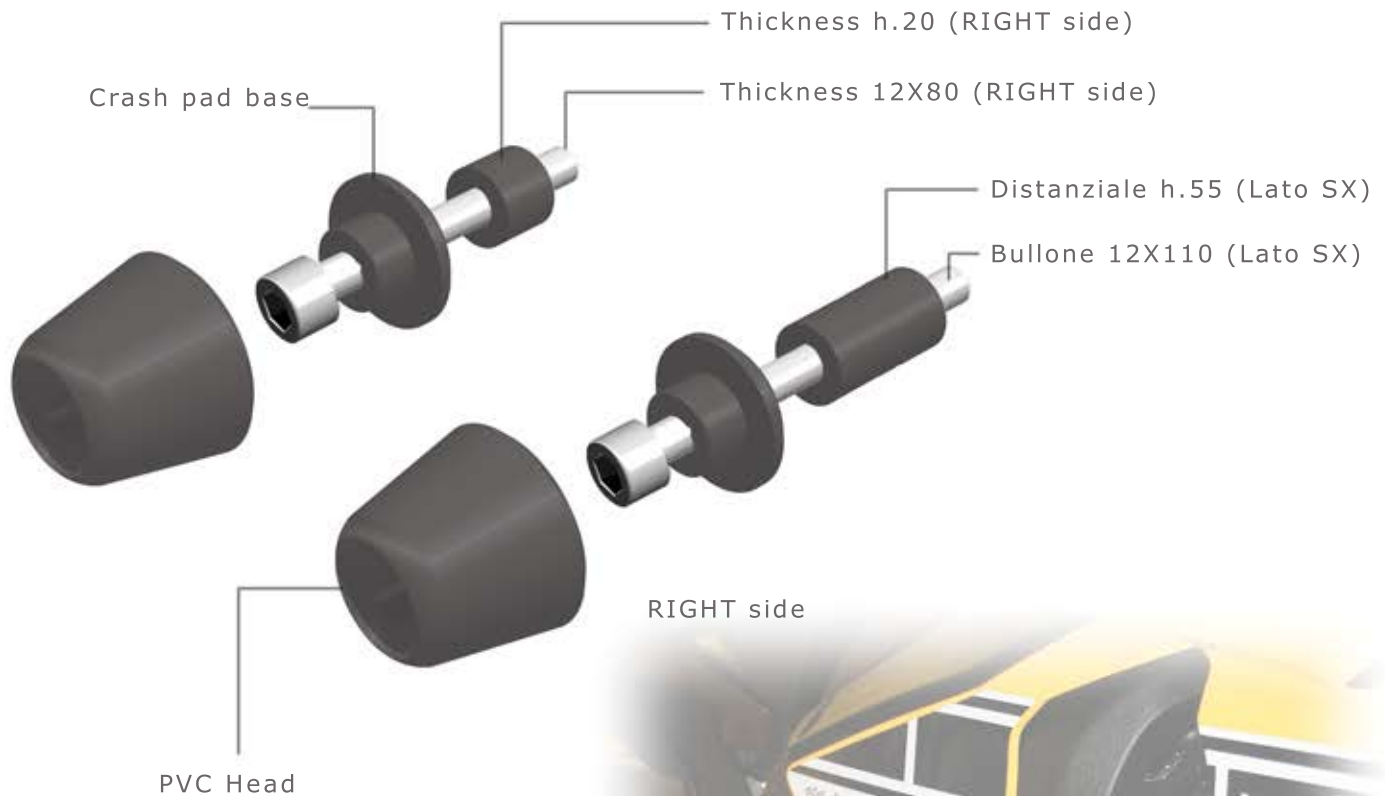

FIND THE FIXING POINT ON THE MOTORBIKE;

USE THE THICKNESS AND BOLTS LIKE DESCRIBED INTO THE PICTURE TO OBTAIN THE RIGHT CRASH PAD PROJECTION FROM THE MOTORBIKE;

FIX THE PVC HEAD AFTER FIXED AND LOCKED ALL THE KIT.