

**MOUNTING PROCEDURE**

KIT LICENCE PLATE  
YAMAHA R1 2015

**YP1104/15**

[WWW.BARRACUDAMOTO.COM](http://WWW.BARRACUDAMOTO.COM)

**KIT**

X1. SPECIFIC BRACKET  
X3. SCREW 6X30 "ROUND HEAD"  
X3. AUTOLOCK NUT Ø 6  
X1. WASHER Ø 6  
X3. WASHER Ø 6 LARGE  
X1. "X" LICENCE PLATE

**FIXING PROCEDURE:**

- REMOVE THE ORIGINAL LICENCE PLATE AND FIX THE BARRACUDA LICENCE PLATE USING THE SCREWS 6X30 LIKE SHOWM THE MOUNTING SCHEME;
- LOCK THE SCREWS AND REPEAT THE OPERATION FOR ALL THE FIXING POINT OF BRACKET;
- APPLY THE "X" LICENCE PLATE TO THE JUNCTION OF SPECIFIC BRACKET;

Autolock nut Ø 6

Large washer Ø 6

Washer Ø 6

Specific bracket

Screw 6x30

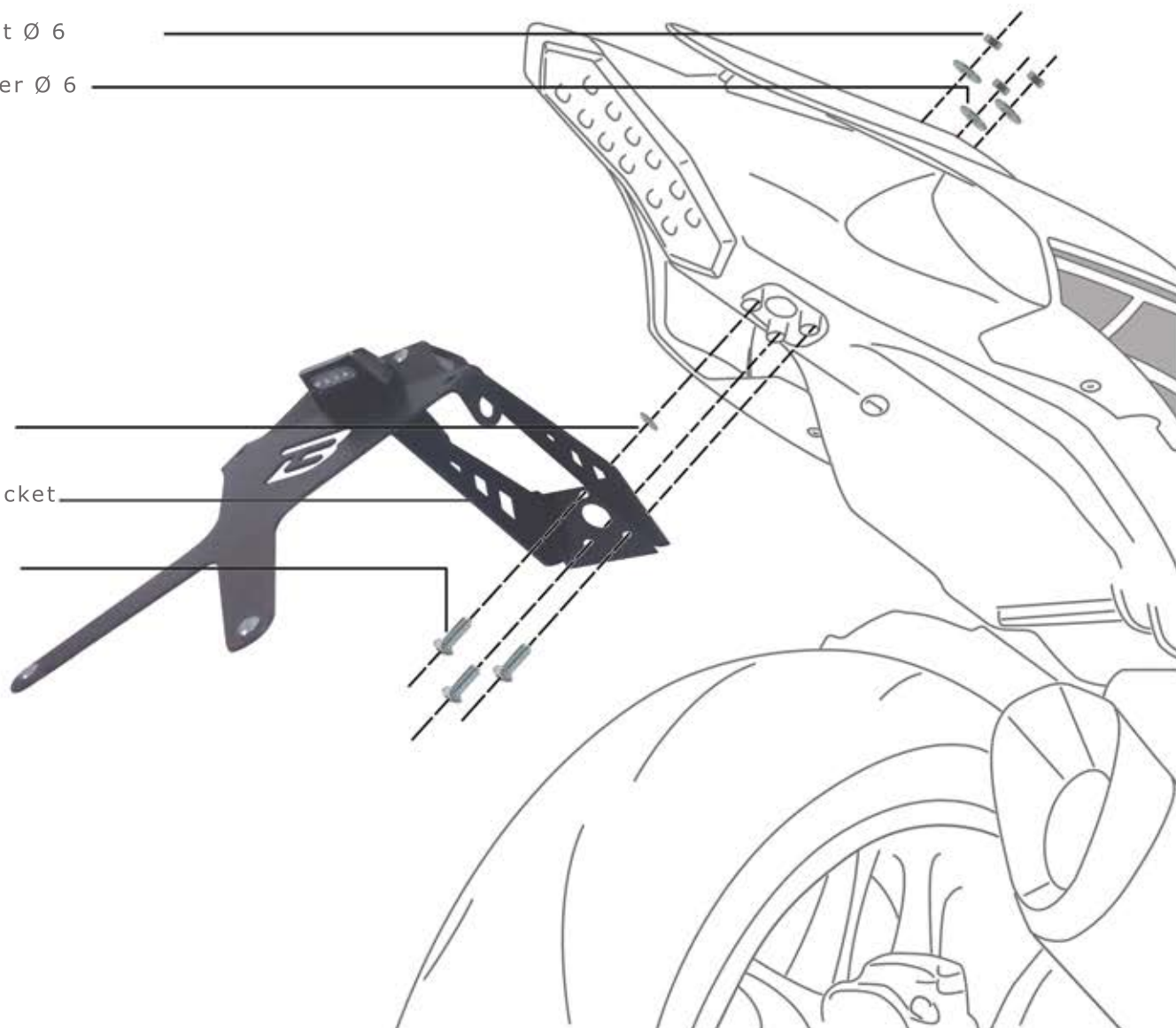

NOTE: WE ADVISE TO TAKE AN INCLINATION NOT EXCEEDING 30° TO AVOID STRUCTURAL POSSIBLE BROKEN