

A137A-A137A

ATTACCHI SPECIFICI PER 137A - SPECIFIC FITTING KIT FOR 137A,
KIT DE MONTAGE SPECIFIQUE POUR 137A - SPEZIFISCHER MONTAGEKIT FÜR 137A

KYMCO PEOPLE S 2005

50/125/200cc

ISTRUZIONI DI MONTAGGIO - MOUNTING INSTRUCTIONS
INSTRUCTIONS DE MONTAGE - BAUANLEITUNG - INSTRUCCIONES DE MONTAJE

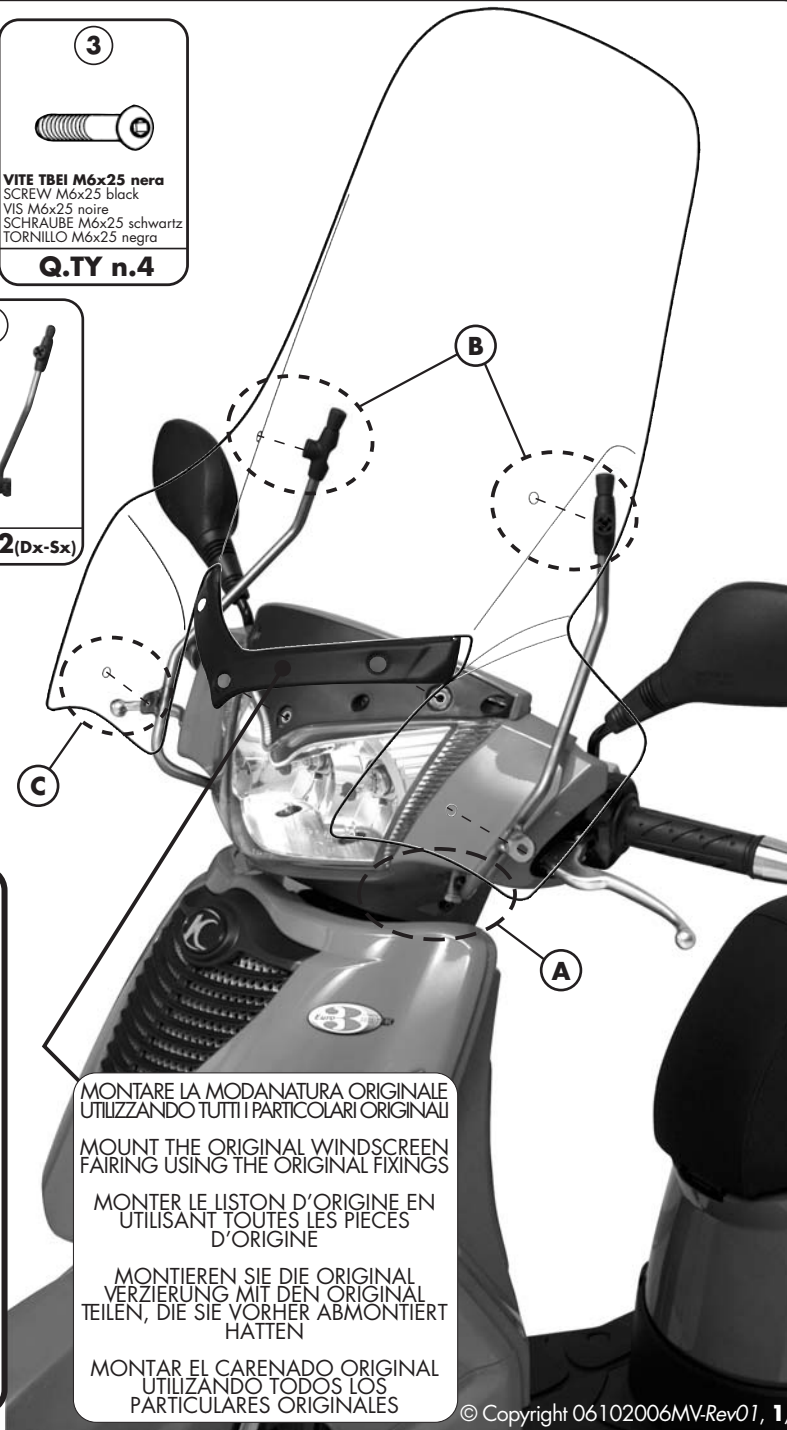
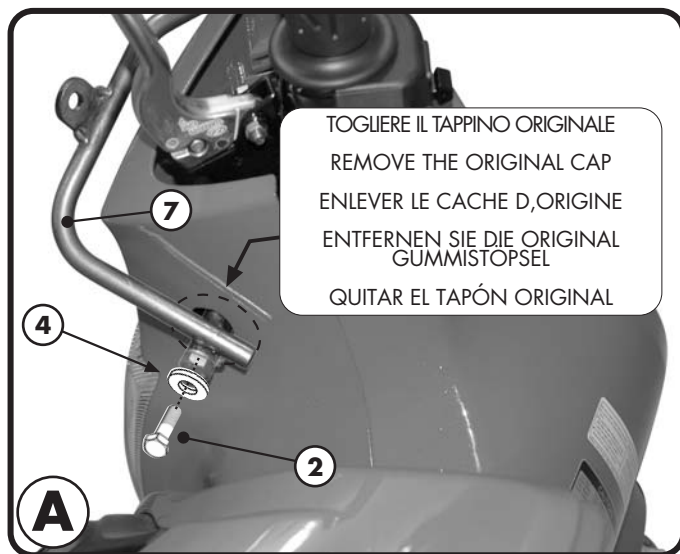
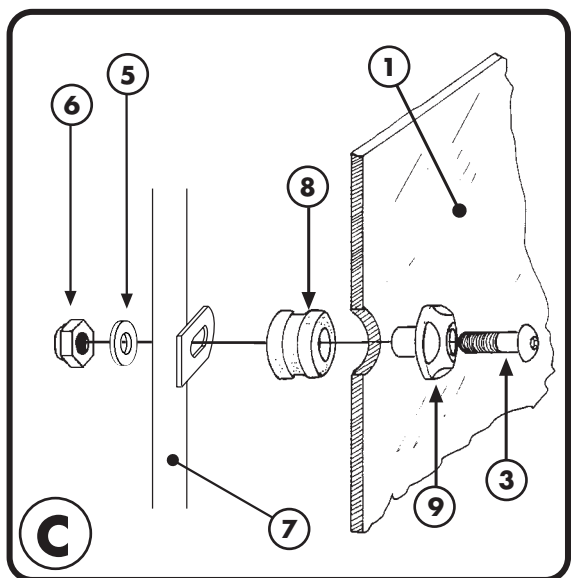
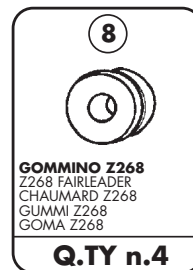
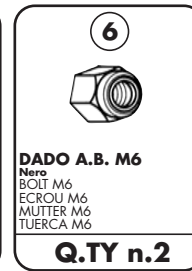
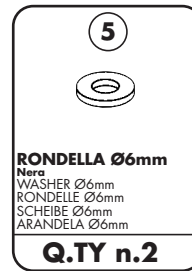
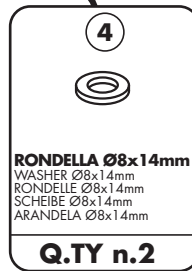
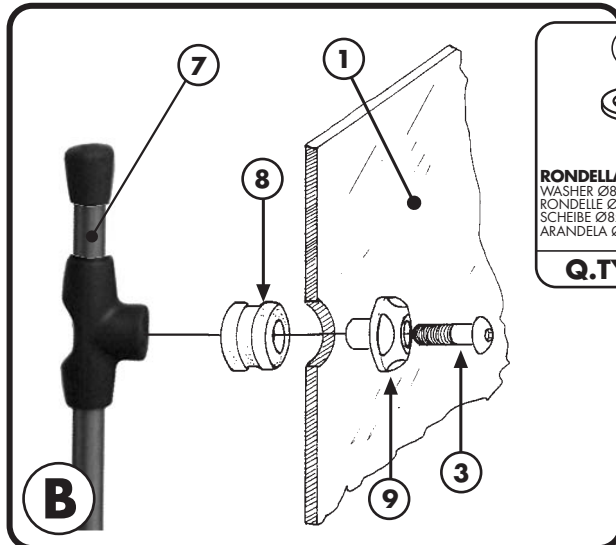
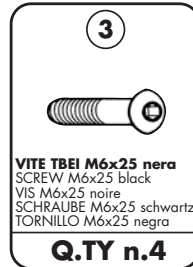
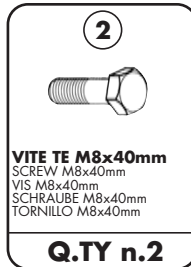

MONTARE LA MODANATURA ORIGINALE
UTILIZZANDO TUTTI I PARTICOLARI ORIGINALI
MOUNT THE ORIGINAL WINDSCREEN
FAIRING USING THE ORIGINAL FIXINGS
MONTER LE LISTON D'ORIGINE EN
UTILISANT TOUTES LES PIÈCES
D'ORIGINE
MONTIEREN SIE DIE ORIGINAL
VERZIERUNG MIT DEN ORIGINAL
TEILEN, DIE SIE VORHER ABMONTIERT
HATTEN
MONTAR EL CARENADO ORIGINAL
UTILIZANDO TODOS LOS
PARTICULARES ORIGINALES

A137A - A137A

**ATTACCHI SPECIFICI PER 137A - SPECIFIC FITTING KIT FOR 137A,
KIT DE MONTAGE SPECIFIQUE POUR 137A - SPEZIFISCHER MONTAGEKIT FÜR 137A
ANCLAJE ESPECIFICO PARA 137A**

KYMC O PEOPLE S 2005
50/125/200cc

ISTRUZIONI DI MONTAGGIO - MOUNTING INSTRUCTIONS
INSTRUCTIONS DE MONTAGE - BAUANLEITUNG - INSTRUCCIONES DE MONTAJE

I ISTRUZIONI DI MONTAGGIO

1. SMONTARE IL PARABREZZA ORIGINALE;
2. MONTARE LE ASTE DI SUPPORTO PARABREZZA N°10 COME MOSTRATO IN FOTOGRAFIA; FAR RIFERIMENTO ALLE IMMAGINI INDICATE NELLA FOTOGRAFIA PRINCIPALE PER IL MONTAGGIO DELLE SINGOLE ZONE DEL PARABREZZA;
3. RIMONTARE LA MODANATURA ORIGINALE RIUTILIZZANDO I PARTICOLARI ORIGINALI PRECEDENTEMENTE SMONTATI;
4. ULTIMARE IL MONTAGGIO CONTROLLANDO CHE TUTTE LE VITI SIANO SERRATE BENE.

GB MOUNTING INSTRUCTIONS

1. REMOVE THE ORIGINAL WINDSCREEN AND FAIRING.
2. MOUNT THE SUPPORTING BARS N° 10 OF THE WINDSCREEN AS SHOWN IN THE PICTURE. REFER TO THE MAIN PICTURE FOR CONNECTION OF ALL REMAINING PARTS.
3. REMOUNT THE ORIGINAL WINDSCREEN FAIRING USING THE ORIGINAL FIXINGS PREVIOUSLY REMOVED.
4. FINALLY CHECK THAT ALL SCREWS HAVE BEEN TIGHTENED.

F INSTRUCTIONS DE MONTAGE

1. DEMONTER LE PARE-BRISE D'ORIGINE ;
MONTER LES BARRES DE SUPPORT DU PARE-BRISE N°10
COMME MONTRE SUR LA PHOTO ;
2. SE REFERER AUX AUTRES PHOTOS POUR CE QUI EST DES
DETAILS PARTICULIERS DE MONTAGE ;
3. REMONTER LE LISTON D'ORIGINE EN UTILISANT LES PIECES
D'ORIGINE PRECEDEMMENT DEMONTEES ;
4. FINIR LE MONTAGE EN CONTROLANT LE BON SERRAGE
DE TOUTES LES VIS.

D BAUANLEITUNG

1. ENTFERNEN SIE DIE ORIGINAL SCHEIBE AB;
2. MONTIEREN SIE DIE STUTZSTANGEN DES
WINDSCHILDES NR. 10 WIE IN DEM BILD
BESCHRIEBEN; NEHMEN SIE AUF DAS HAUPTBILD
BEZUG FÜR DIE MONTAGE DER EINZELNEN TEILE
DES WINDSCHILDES;
3. MONTIEREN SIE DIE ORIGINAL VERZIERUNG MIT
DEN ORIGINAL TEILEN, DIE SIE VORHER ABMONTIERT
HATTEN;...
4. ZULETZT ÜBERPRÜFEN SIE, DASS ALLE SCHEIBEN
ABMONTIERT WURDEN.

ES

INSTRUCCIONES DE MONTAJE

- 1 DESMONTAR EL PARABRISAS ORIGINAL
- 2 MONTAR LAS ASTAS DE SOPORTE PARABRISAS N. 10 COMO MOSTRADO EN FOTOGRAFÍA; HACER REFERENCIA A LAS IMAGINES INDICADAS EN LA FOTOGRAFÍA PRINCIPAL PARA EL MONTAJE DE LAS SINGULAS ZONAS DEL PARABRISAS
- 3 VOLVER A MONTAR EL CARENADO ORIGINAL UTILIZANDO LOS PARTICULARES ORIGINALES PREVIAMENTE DESMONTADOS
- 4 TERMINAR EL MONTAJE COMPROBANDO QUE TODOS LOS TORNILLOS SEAN CERRADOS BIEN.