

SR311 - KR311

PORTAVALIGIA SPECIFICO - SPECIFIC CASE HOLDER
PORTE-VALISE SPECIFIQUE - SPEZIFISCHER KOFFER-TRÄGER
PORTA-EQUIPAJE ESPECIFICO

DUCATI MULTISTRADA '06/'08 620/1100cc

ISTRUZIONI DI MONTAGGIO - MOUNTING INSTRUCTIONS
INSTRUCTIONS DE MONTAGE - BAUANLEITUNG - INSTRUCCIONES DE MONTAJE



1
SUPPORTO
SUPPORT
SUPPORT
HALTERUNG
SOPORTE

Q.TY n.1

2

PIASTRA MONOKEY
Z622M
PLATE
PLATINE
PLATTE
PARRILLA

Q.TY n.1

3



VITE TCEI M6x35mm
SCREW M6x35mm
VIS M6x35mm
SCHRAUBE M6x35mm
TORNILLO M6x35mm

Q.TY n.4

4



RONDELLA Ø6mm
WASHER Ø6mm
RONDELLE Ø6mm
SCHEIBE Ø6mm
ARANDELA Ø6mm

Q.TY n.4

5



DADO A.B. M6
BOLT M6
ECROU M6
MUTTER M6
TUERCA M6

Q.TY n.4

6



COPRIFORO
Z621
BOLT CAP
CACHE TROU
STOPLOCK
TAPA AGUJERO

Q.TY n.6

7



RONDELLA Ø6x18mm
WASHER Ø6x18mm
RONDELLE Ø6x18mm
SCHEIBE Ø6x18mm
ARANDELA Ø6x18mm

Q.TY n.4

8



VITE TSCEI M6x45mm
SCREW M6x45mm
VIS M6x45mm
SCHRAUBE M6x45mm
TORNILLO M6x45mm

Q.TY n.4

9



VITE TBEI M6x16mm
SCREW M6x16mm
VIS M6x16mm
SCHRAUBE M6x16mm
TORNILLO M6x16mm

Q.TY n.4

10

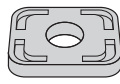

GOMMINO
Z1822
RUBBER
CAOUTCHOUC
GUMMI
GOMA

Q.TY n.4

11



DISTANZIALE Ø11x11mm
foro Ø6,5mm
V687
SPACER
ENTRETOISE
DISTANZSTUECK
DISTRANCIADOR

Q.TY n. 4

ATTENZIONE: PESO MASSIMO SOPPORTABILE 10Kg.

WARNING: MAX. LOADING OF THE CARRIER 10Kg.(21lbs)

ATTENTION: CHARGE MAXIMALE 10Kg.

ACHTUNG: MAXIMALE BELASTUNG 10Kg.

¡ATENCIÓN!: CARGA MÁXIMA AUTORIZADA 10Kg.

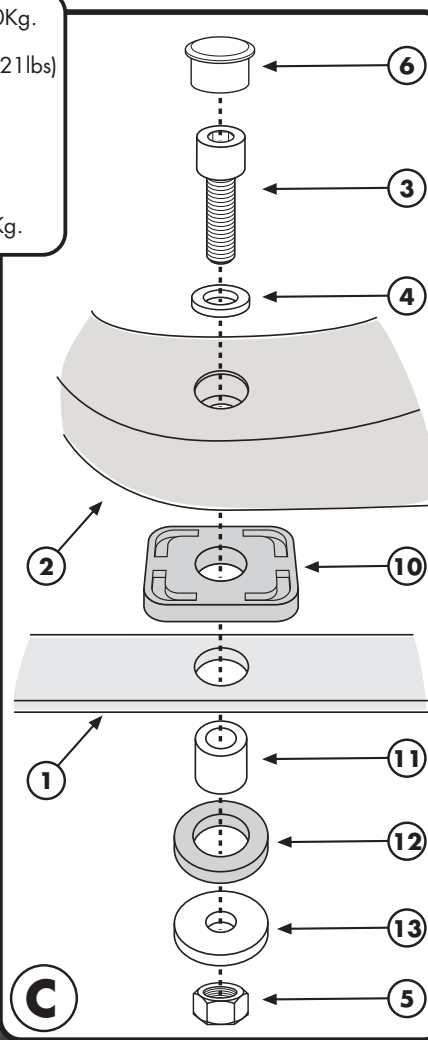
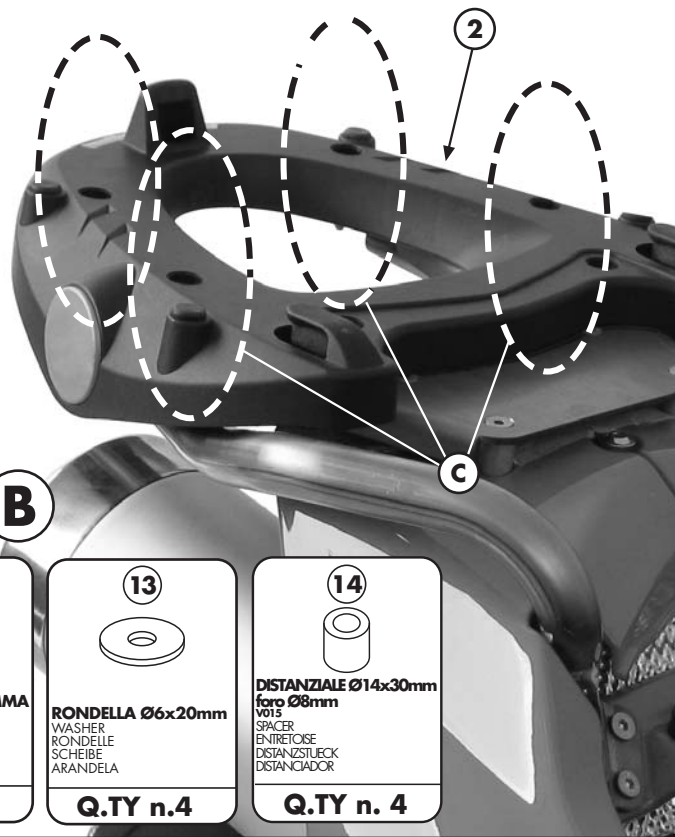
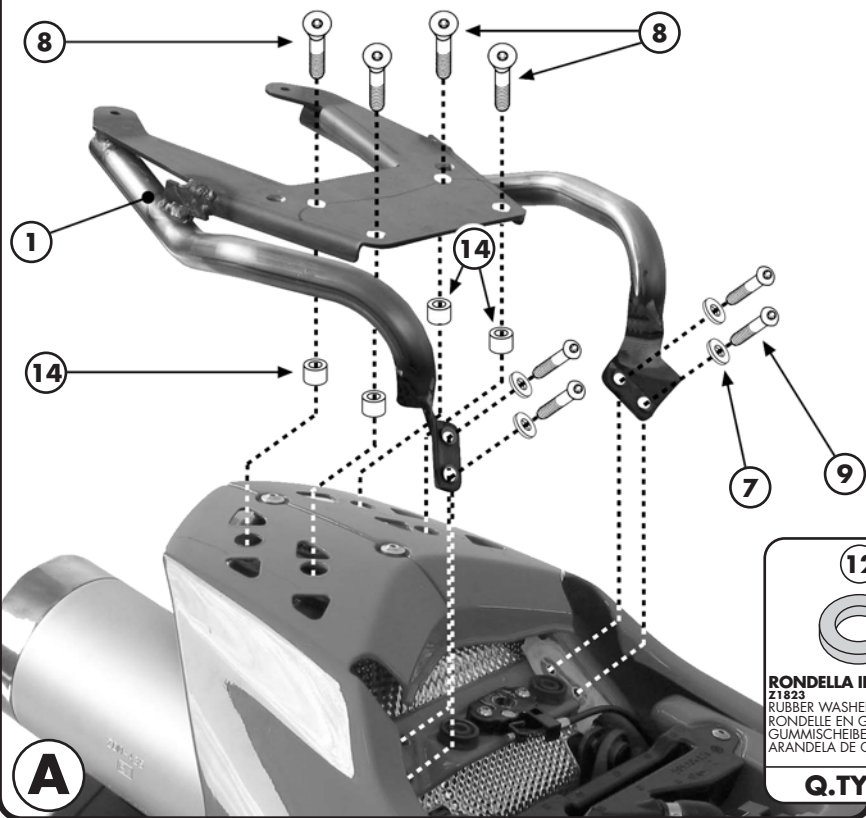

12



RONDELLA IN GOMMA
Z1823
RUBBER WASHER
RONDELLE EN GOMME
GUMMISCHEIBE
ARANDELA DE GOMA

Q.TY n.4

13



RONDELLA Ø6x20mm
WASHER
RONDELLE
SCHEIBE
ARANDELA

Q.TY n.4

14



DISTANZIALE Ø14x30mm
foro Ø8mm
V015
SPACER
ENTRETOISE
DISTANZSTUECK
DISTRANCIADOR

Q.TY n. 4

PORTAVALIGIA SPECIFICO - SPECIFIC CASE HOLDER
 PORTE-VAISE SPECIFIQUE - SPEZIFISCHER KOFFER-TRÄGER
 PORTA-EQUIPAJE ESPECÍFICO

DUCATI MULTISTRADA '06/'08
620/1100cc

ISTRUZIONI DI MONTAGGIO - MOUNTING INSTRUCTIONS
 INSTRUCTIONS DE MONTAGE - BAUANLEITUNG - INSTRUCCIONES DE MONTAJE

I ISTRUZIONI DI MONTAGGIO

1. SMONTARE IL MANIGLIONE ORIGINALE DALLA CODA DELLA MOTOCICLETTA;
2. TOGLIERE LE GUARNIZIONI IN GOMMA ORIGINALI;
3. POSIZIONARE IL SUPPORTO N°1 COME MOSTRATO IN FOTO A;
4. CONTROLLARE CHE LE VITI SIANO SERRATE BENE;
5. MONTARE LA PIASTRA, PARTICOLARE N°2, COME INDICATO IN FOTO B;
6. ULTIMARE IL MONTAGGIO CONTROLLANDO CHE TUTTE LE VITI SIANO SERRATE BENE.

GB MOUNTING INSTRUCTIONS

1. REMOVE THE ORIGINAL HANDLEBAR OF THE REAR FAIRING;
2. REMOVE THE ORIGINAL RUBBER WASHERS;
3. PLACE THE SUPPORT N° 1 AS SHOWN IN PICTURE A;
4. CHECK THAT THE SCREWS HAVE BEEN TIGHTENED;
5. MOUNT THE PLATE, PART N° 2, AS SHOWN IN PICTURE B;
6. LASTLY CHECK THAT ALL SCREWS ARE TIGHT.

F INSTRUCTIONS DE MONTAGE

1. DEMONTER LES POIGNEES PASSGER D'ORIGINE DE SUR LA MOTO;
2. ENLEVER LES PROTECTIONS CAOUTCHOUC D'ORIGINE;
3. POSITIONNER LE SUPPORT N°1 COMME MONTRE SUR LA PHOTO A;
4. CONTROLER LE BON SERRAGE DES VIS;
5. MONTER LA PLATINE, PIECE N°2, COMME INDIQUE SUR LA PHOTO B;
6. TERMINER LE MONTAGE EN CONTROLANT LE BON SERRAGE DE TOUTES LES VIS.

D BAUANLEITUNG

1. NEHMEN SIE DEN ORIGINAL HANDGRIFF DES FAHRZEUGSHECKS AB;
2. ENTFERNEN SIE DIE ORIGINAL GUMMIDICHTUNGEN;
3. POSITIONIEREN SIE DIE HALTERUNG NR. 1 WIE IM BILD A BESCHRIEBEN;
4. ÜBERPRÜFEN SIE, DASS ALLE SCHRAUBEN FESTGEZOGEN WURDEN;
5. MONTIEREN SIE DIE PLATTE, TEIL NR. 2, WIE IM BILD B BESCHRIEBEN;
6. ZULETZT ZIEHEN SIE ALLE SCHRAUBEN FEST.

ES

INSTRUCCIONES DE MONTAJE

1. DESMONTAR EL ASA ORIGINAL DEL COLÍN DE LA MOTO,
2. QUITAR LA JUNTAS ORIGINALES EN GOMA;
3. MONTAR EL SOPORTE N° 1 COMO ENSEÑA LA FOTO A;
4. CONTROLAR QUE TODOS LOS TORNILLOS ESTÉN BIEN APRETADO;
5. MONTAR LA PARRILLA N° 2 COMO INDICA LA FOTO B;
6. TERMINAR APRETANDO TODOS LOS TORNILLOS